



Materials – Revision Notes 2017

Plastics

Acrylic		Stiff and brittle.	Used to make signs and small 2D and 3D forms
Polyvinyl sheet (PVC)		Stiff, strong, tough and resists scratching	Used to make 2D and 3D shapes and may be used for vacuum-forming
Polystyrene foam (Styrofoam)		Brittle in tension, lightweight, with good heat and sound insulation	Available in blocks and used for product-modelling
Cellophane		Tough, hard, stiff, lightweight, transparent, and non-flammable	Used for wrapping round products
Polythene		Hard, stiff and able to be sterilised	Used to make bottles and for shrink-wrapping products.



What is the difference between thermoplastic and thermosetting plastics?

The primary physical **difference** is that **thermoplastics** can be remelted back into a liquid, whereas **thermoset plastics** always remain in a permanent solid state. Think of **thermoplastics** as butter – butter can be melted and cooled multiple times to form various shapes.

Nets

 <p>How would you draw the net for a simple box?</p>	<p>What is a net?</p> <p>A net is often called a development net. It is a flat two dimensional shape, which contains score lines and when is folded and glued together forms a three dimensional shape. Nets are often used for packaging items such as orange cartons, point of sale display units, tissue boxes and so on.</p>
	<p>Net shapes</p> <p>When a net is made it is important that the net keeps some symmetry. All opposite edges must be equal so that when you fold them together they are the same length. Nets also need flaps or tabs, these flaps or tabs are drawn on the outside of the nets and are glued under the net to keep it together. Please look below at the net and made up box.</p>

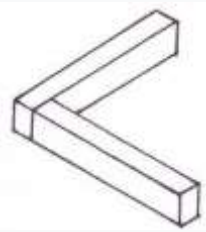
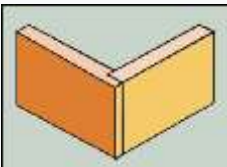
Wood Joints

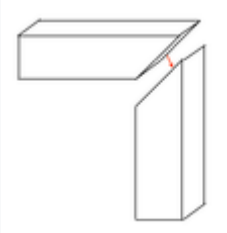
Joint	Image	Description
Butt joint		<p>The end of a piece of wood is butted against another piece of wood. This is the simplest and weakest joint.</p>
Lap joint		<p>The end of a piece of wood is laid over and connected to another piece of wood. This is the next simplest and weakest joint.</p>
Dowel joint		<p>The end of a piece of wood is butted against another piece of wood. This is reinforced with dowel pins. This joint is quick to make with production line machinery and so is a very common joint in factory-made furniture.</p>
Mitre joint		<p>Similar to a butt joint, but both pieces have been bevelled (usually at a 45 degree angle).</p>

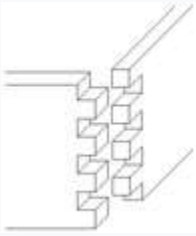
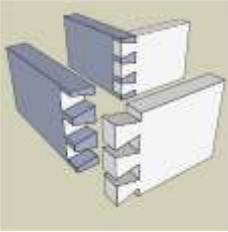
<p>Finger joint</p>		<p>Also known as a box joint, is a corner joint with interlocking fingers. Receives pressure from two directions.</p>
<p>Dovetail joint</p>		<p>A form of box joint where the fingers are locked together by diagonal cuts. More secure than a finger joint.</p>

Marking out







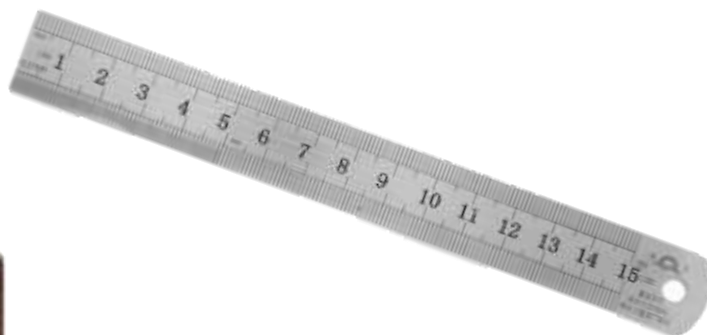
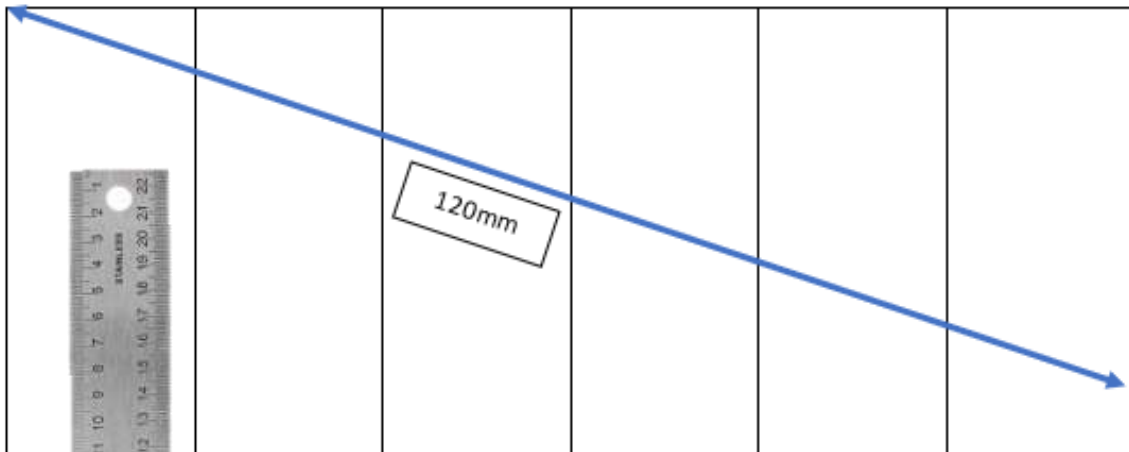

Marking out or layout means the process of transferring a design or pattern to a workpiece, as the first step in the manufacturing process. It is performed in many industries or hobbies although in the repetition industries the machine's initial setup is designed to remove the need to **mark out** every individual piece.

With our boxes we split the length of wood into equal parts by

1. Placing the ruler at zero and moving it so that it was at a number easily divisible by 6 = 120mm.
2. Drawing vertical lines up with a set square.



Basic tools

Coping saw		To Cutting curves in various materials.
Tenon Saw		Cutting straight lines in wood.
Mallet		Provides impact for chisel
Chisel		Sharp blade to remove slices of wood.
Screwdriver		To inset a screw
Screw		To fasten two surfaces together
Cross pein hammer		To impact a hammer for a nail or pin
Tri square		To check if two surfaces are 90°

Panel pins		Fine gauge nail designed specifically for delicate jobs
------------	---	---

Isometric Drawing

Isometric projection is a method for visually representing three-dimensional objects in two dimensions in technical and engineering drawings.

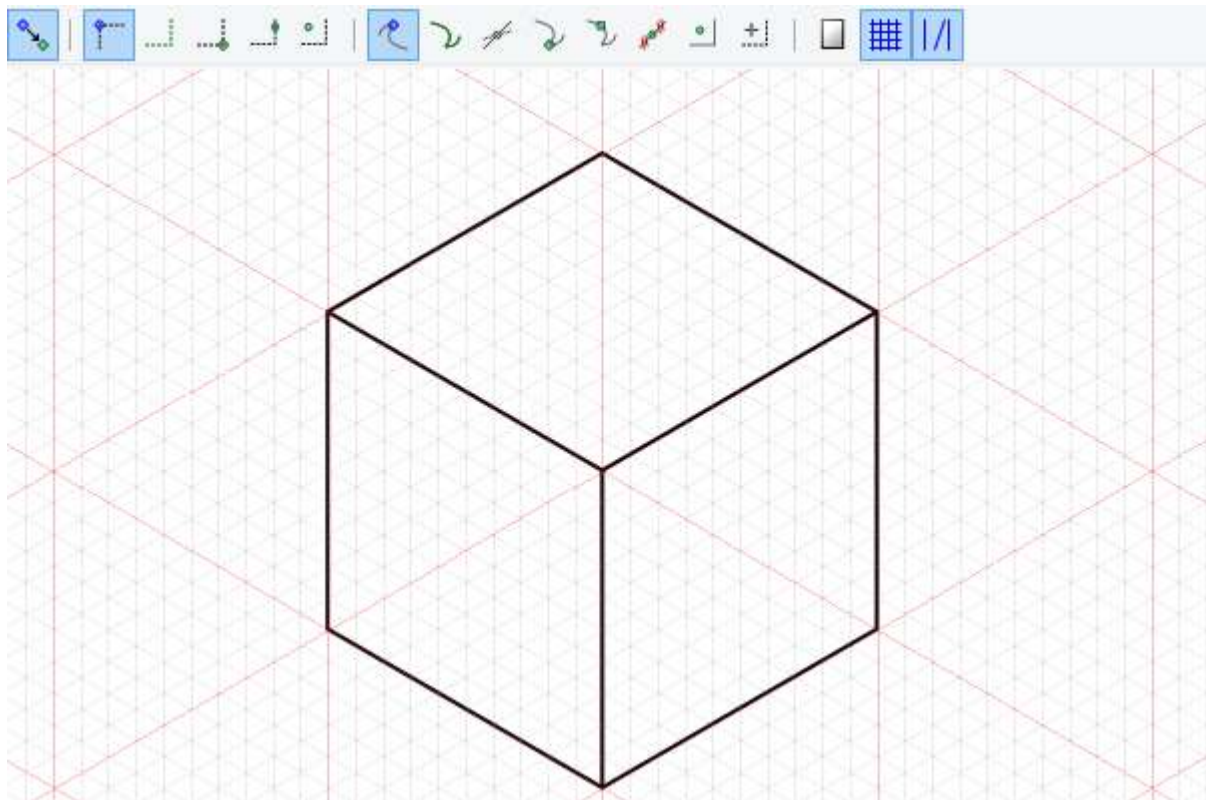

Enterprise

Enterprise is a skill. Put simply, enterprise is the willingness of an individual or organisation to:

- **Take risks.** Setting up a new business is risky. Even if the entrepreneur has carefully researched the market, there's always a chance that customers may reject the product and that a loss will be made.
- **Show initiative** and '**make things happen**'. Successful entrepreneurs have the drive, determination and energy to overcome hurdles and launch new businesses.
- **Undertake new ventures.** An entrepreneur has to have the imagination to spot business opportunities that will fill gaps in the market.